

CITIZEN®

# USER'S MANUAL

*Thermal Label & Barcode Printer*

# CLP-521

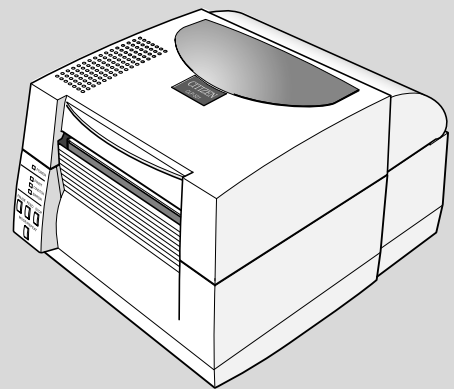

# CONTENTS

## Before Operation

Introduction .....	3
COMPLIANCE STATEMENT FOR EUROPEAN USERS .....	4
FCC COMPLIANCE STATEMENT FOR AMERICAN USERS .....	4
EMI COMPLIANCE STATEMENT FOR CANADIAN USERS .....	5
ETAT DE CONFORMITE EMI A L'USAGE DES UTILISATEURS CANADIENS .....	5
Important Safety Instructions .....	6
Notice .....	7
SAFETY INSTRUCTIONS .....	8

## Chapter 1 Setup

Confirmation of Carton Contents .....	10
Part Names and Functions .....	11
Connection to Power .....	16
Driver Installation .....	16
Connection to a Computer .....	17

## Chapter 2 Printer Operation

Power ON/OFF .....	18
Normal Operating Mode .....	19
Setting the Media .....	21
Mode Settings .....	25

## Chapter 3 Printer Adjustments

Sensor Adjustments .....	34
Media Thickness Adjustment .....	37
Media Width Adjustment .....	38
Cleaning .....	39

## Chapter 4 Troubleshooting ----- 40

## Appendixes

Specifications .....	42
Interfaces .....	45
Replacing the Interface Board .....	51

# INTRODUCTION

Thank you very much for purchasing Citizen's compact direct thermal label & barcode printer Model CLP-521 that offers high performance printing at 4 inches per second on 4.1 inch media at very low cost.

## //// Main Features ////

### **<High-speed, high-quality printing>**

This printer can be used for high-speed high-quality printing thanks to its thermal-transfer system that uses a line thermal head together with its 32 bit RISC CPU and its 'history control IC'.

### **<Easy operation>**

- It is easy to change the printer's settings on the operation panel, thanks to its unique and simple VuePrint menu system.
- Its high-lift printhead and mechanism means that media can be loaded with ease and it is constructed for easy head cleaning, etc.
- Media width adjustment, media thickness adjustment, and media sensor adjustment can all be made easily by the user using the colour-coded operator controls.

### **<Interface>**

In addition to a serial port, an IEEE1284 (ECP mode) and USB1.1 are standard equipment, for quick data transfer and printing.

### **<Optional interface>**

The CLP-521 has an optional internally housed Ethernet (LAN) and a wireless LAN (WiFi) print server.

### **<Optional auto-cutter / peeler unit>**

Its auto-cutter and peeler unit are constructed so they can be replaced easily.

### **<Adjustable sensors>**

The adjustable sensors that permit the adjustment of the positions of the media gap or the black mark detection sensor in the media width direction are standard equipment that can detect the position of special media.

### **<Installation>**

The interface, power switch etc. are installed towards the back and the top cover opens and closes vertically so that the sides of the printer are not restricted.

## **COMPLIANCE STATEMENT FOR EUROPEAN USERS**

CE marking shows conformity to the following criteria and provisions:

Low Voltage Directive (73/23/EEC)/EN60950

EMC Directive (89/336/EEC)/EN55022, EN55024, EN61000-3-2 & EN61000-3-3

## **FCC COMPLIANCE STATEMENT FOR AMERICAN USERS**

This equipment has been tested and found to comply with the limits for a Class A digital device, pursuant to Part 15 of the FCC Rules. These limits are designed to provide reasonable protection against harmful interference when the equipment is operated in a commercial environment. This equipment generates, uses, and can radiate radio frequency energy and, if not installed and used in accordance with the instruction manual, may cause harmful interference to radio communications. Operation of this equipment in a residential area is likely to cause harmful interference in which case the user will be required to correct the interference at his own expense.

# EMI COMPLIANCE STATEMENT FOR CANADIAN USERS

This equipment generates and uses radio frequency energy and if not installed and used properly, that is, in strict accordance with the manufacturer's instructions, may cause interference to radio and television reception. This digital apparatus does not exceed the Class A limits for radio noise emissions from digital apparatus set out in the Radio Interference Regulations of the Canadian Department of Communications. This equipment is designed to provide reasonable protection against such interference in a residential installation. However, there is no guarantee that interference will not occur in a particular installation. If this equipment does cause interference to radio or television reception, which can be determined by turning the equipment off and on, the user is encouraged to try to correct the interference by one or more of the following measures:

- Reorient or relocate the receiving antenna.
- Increase the separation between the equipment and receiver.
- Connect the equipment into an outlet on a circuit different from that to which the receiver is connected.
- Consult the dealer or an experienced radio/TV technician for help.

**CAUTION:** Use shielded cables to connect this device to computers.

Any changes or modifications not expressly approved by the grantee of this device could void the user's authority to operate the equipment.

## ETAT DE CONFORMITE EMI A L'USAGE DES UTILISATEURS CANADIENS

Cet équipement produit et utilise l'énergie à radiofréquences et s'il n'est pas installé et utilisé correctement, c'est à dire en accord strict avec les instructions du fabricant, il risque de provoquer des interférences avec la réception de la radio et de la télévision.

Le présent appareil numérique n'émet pas de bruits radio électriques dépassant les limites applicables aux appareils numériques de la classe A prescrites dans le Règlement sur le brouillage radioélectrique édicté par le ministère des Communications du Canada.

Cet équipement est conçu pour fournir une protection satisfaisante contre de telles interférences dans une installation résidentielle. Cependant, il n'y a pas de garantie contre les interférences avec les réceptions radio ou télévision, provoquées par la mise en et hors circuit de l'équipement; aussi, il est demandé à l'utilisateur d'essayer de corriger l'interférence par l'une ou plus des mesures suivantes:

- Réorienter l'antenne de réception.
- Installer l'ordinateur autre part, par égard pour le récepteur.
- Brancher l'ordinateur dans une prise de courant différente de façon à ce que l'ordinateur et le récepteur soient branchés sur des circuits différents.

# Important Safety Instructions

- Read all of these instructions and save them for later reference.
- Follow all warnings and instructions marked on the product.
- Unplug this product from the wall outlet before cleaning. Do not use liquid or aerosol cleaners. Use a damp cloth for cleaning.
- Do not use this product near water.
- Do not place this product on an unstable cart, stand or table. The product may fall, causing serious damage to the product.
- Slots and openings on the cabinet and the back or bottom are provided for ventilation. To ensure reliable operation of the product and to protect it from overheating, do not block or cover these openings. The openings should never be blocked by placing the product on a bed, sofa, rug or other similar surface. This product should never be placed near or over a radiator or heat register. This product should not be placed in a built-in installation unless proper ventilation is provided.
- This product should be operated from the type of power source indicated on the marking label. If you are not sure of the type of power available, consult your dealer or local power company.
- This product is equipped with a three-pronged plug, a plug having a third (grounding) pin. This plug will only fit into a grounding-type power outlet. This is a safety feature. If you are unable to insert the plug into the outlet, contact your electrician to replace your obsolete outlet. Do not defeat the safety purpose of the grounding-type plug.
- Do not allow anything to rest on the power cord. Do not locate this product where the cord will be walked on.
- If an extension cord is used with this product, make sure that the total of the ampere ratings on the products plugged into the extension cord do not exceed the extension cord ampere rating. Also, make sure that the total of all products plugged into the wall outlet does not exceed 15 amperes for 120V outlet and 7.5 amperes for 220V-240V outlet.
- Never push objects of any kind into this product through cabinet slots as they may touch dangerous voltage points or short out parts that could result in a risk of fire or electric shock. Never spill liquid of any kind on the product.
- Except as explained elsewhere in this manual, don't attempt to service this product yourself. Opening and removing those covers that are marked "Do Not Remove" may expose you to dangerous voltage points or other risks. Refer all servicing on those compartments to service personnel.
- The mains plug on this equipment must be used to disconnect mains power. Please ensure that the socket outlet is installed near the equipment and shall be easily accessible.
- Unplug this product from the wall outlet and refer servicing to qualified service personnel under the following conditions:
  - A. When the power cord or plug is damaged or frayed.
  - B. If liquid has been spilled into the product.
  - C. If the product has been exposed to rain or water.
  - D. If the product does not operate normally when the operating instructions are followed. Adjust only those controls that are covered by the operating instructions since improper adjustment of other controls may result in damage and will often require extensive work by a qualified technician to restore the product to normal operation.
  - E. If the product has been dropped or the cabinet has been damaged.
  - F. If the product exhibits a distinct change in performance, indicating a need for service.



# Notice

- Before use, be sure to read this manual. And keep it handy for reference when needed.
- The contents of this manual may change without prior notice.
- Reproduction, transfer, or transmission of the contents of this manual without prior consent is strictly prohibited.
- We are not liable for any damage resulting from the use of the information contained herein, regardless of errors, omissions, or misprints.
- We are not liable for any problems resulting from the use of optional products and consumable supplies other than the designated products contained herein.
- Do not handle, disassemble or repair the parts other than those specified in this manual.
- We are not liable for any damage caused by user's erroneous use of the printer and inadequate environment.
- Data residing in the printer is temporary. Therefore, all data will be lost if power is lost. We are not liable for any damage or loss of profits caused by data loss due to failures, repairs, inspections, etc.
- Please contact us if there are any mistakes or ambiguities within this manual.
- If there are missing or incorrectly collated pages in this manual, contact us to obtain a new manual.

# SAFETY INSTRUCTIONS

## which must be strictly observed !

- To prevent personal injury or property damage, the following shall be strictly observed.
- The degree of possible injury and damage due to incorrect use or improperly following instructions is described below.

 <b>Warning</b>	Indicates a situation which, if not observed and handled properly, could result in death or serious injury.
 <b>Caution</b>	Indicates a situation which, if not observed and handled properly, could result in injury.



: This is a mark to call attention to the reader.

### **Warning**

Never perform the following. If not avoided, these may cause damage or trouble to the printer or cause the printer to overheat and release smoke and cause burns or an electrical shock. If the printer is damaged or is malfunctioning, be sure to turn the printer off immediately and remove the power cord from the outlet, then consult our service personnel.

- Do not jolt or impact to the printer by stepping on, dropping or hitting the printer.
- Do not place the printer in a poorly ventilated area, or shut off the air vent of the printer.
- Do not place the printer where chemical reactions occur, such as in laboratories or where air is mixed with salt or gas.
- Do not use a power voltage or frequency other than those specified.
- Do not plug/unplug the power cord or attach/detach the interface cable by simply grabbing the power cord or interface cable. Do not pull or carry the printer when the tension of the power cord or interface cable is increased.
- Do not drop or put foreign matter such as clips and pins into the printer. This may cause problems.
- Do not plug the power cord into an outlet with many loads.
- Do not spill drinks such as tea, coffee and juice on the printer or spray insecticide on the printer. If drink or water is spilled, first be sure to turn the power off and remove the power cord from the outlet, then consult our service personnel.
- Do not disassemble or modify the printer.

Discard or safely store the plastic packing bag. This bag should be kept away from children. If the bag is pulled over a child's head, it may cause suffocation.

## General Precautions

### **Caution**

- Prior to operation, read the safety instructions carefully and observe them.
- Do not drop or put foreign matter such as clips and pins into the printer. This may cause problems.
- Be careful when moving or carrying the printer. Dropping the printer may cause injury or property damage.
- Make sure if you open the top cover, it is opened all the way. If only partially open, the cover could slam shut, possibly causing injury.
- When the cover is open, be careful of the corners of the cover. They could cause injury.
- Do not open the printer during printing.
- When cleaning the surface of the printer case, do not use the cloth that is soaked in thinner, trichloroethylene, benzene, ketone or similar chemicals.
- Do not use the printer where there is a lot of oil, iron particles, or dust.
- Do not spill liquids or spray insecticide on the printer.
- Do not jolt or impact to the printer by stepping on, dropping or hitting the printer.
- Operate the control panel properly. A careless, rough handling may cause problems or malfunction. Do not use such sharp-edged tool as a ballpoint pen for operation.
- Be careful of the edges of the plates so injury or property damage is possible.
- If a problem occurs during printing, stop the printer immediately and unplug the power cord from the outlet.
- When printer trouble occurs, do not try to disassemble it. Instead, consult our service personnel.

## Precautions When Installing the Printer

### **Caution**

- Prior to operation, read the safety instructions carefully and observe them.
- Do not use or store the printer near fire, excessive moisture, in direct sunlight, near an air conditioner or heater or other source of unusually high or low temperature or humidity or excessive dust.
- Do not place the printer where chemical reactions occur, such as in a laboratory.
- Do not place the printer where air is mixed with salt or gas.
- The printer must sit on a firm, level surface where there is ample ventilation. Never allow the printer's air vent to be blocked by a wall or other object.
- Do not put anything on the top of printer.
- Do not place the printer near a radio or television, and do not use the same wall outlet for the printer and radio or television. Radio or television reception could be adversely affected.
- Do not use a power voltage or frequency other than those specified.
- Do not put anything on the power cord or step on it.
- Do not drag or carry the printer with the power cord or interface cable.
- Avoid plugging the power cord into an outlet with many loads.
- Do not bundle the power cord when inserting the plug.
- Always grip the plug housing, not the cord, to plug/unplug the power cord.
- Make certain the power is turned off before connecting/disconnecting the interface cable.
- Avoid lengthening the signal cable or connecting it to any noise-producing device. If it is unavoidable, use the shielded cable or twisted pair for each signal.
- Place the printer near the outlet where the power cord can be unplugged easily to shut off power.
- Use the AC outlet that accepts a three-pronged plug. Otherwise, static electricity may be generated and there will be danger of electric shock.

## Confirmation of Carton Contents

### Removing the Packing Material

The printer is shipped with adhesive tape in place to hold the top cover closed. Simply remove the two pieces of tape on either side of the top cover. Then simply open the cover by lifting up and tipping it backwards.

There is another strip of adhesive tape that must be removed which holds the mechanism closed for shipping. Remove the tape and attached paper by carefully peeling from the plastic case.

Retain the tape should you need to transport the printer again. A further piece of packing paper is inside the mechanism and you can remove this when the head is opened as explained below.

Check that the following accessories are included with the printer in the carton.

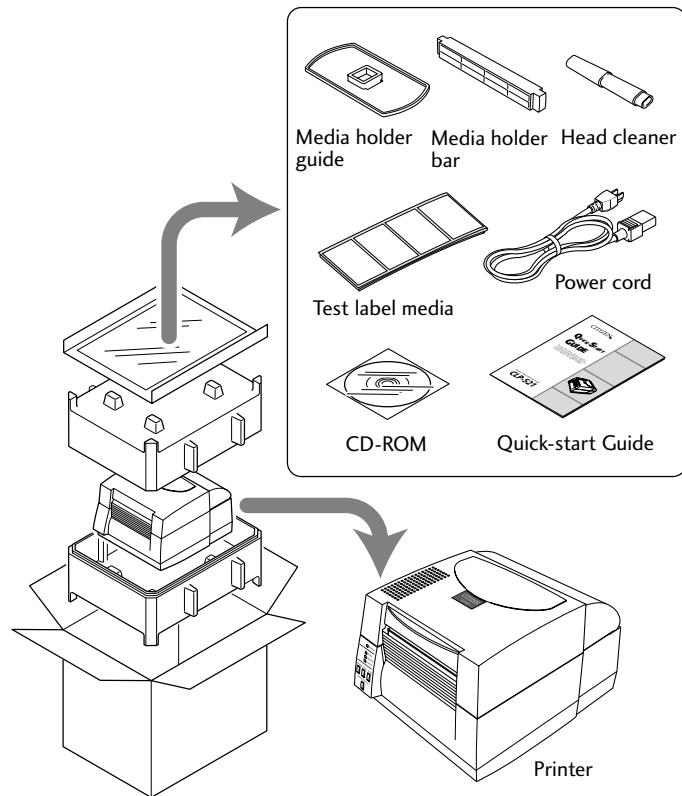

**Note:** The empty carton and packing materials should be stored for future shipping of the printer.

## Part Names and Functions

### Front View

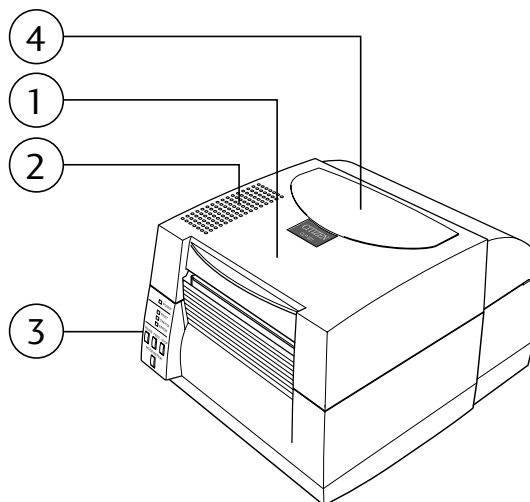

① **Top cover**

Is opened vertically to place or replace media.

② **Heat discharge vent**

It allows warm air to vent from the printer.  
Be sure not to block it with media etc.

③ **Operation panel**

This is used to make changes and adjustments to the printer and its configuration.

④ **Media window**

The amount of media remaining can be checked through this window.

*Operation Panel (p.14)*

### **Caution**

- Be careful when moving or carrying the printer and when taking the printer out of the carton. The printer may cause injury or property damage if dropped. Be sure to grip the printer housing firmly when taking it out of the carton. Do not grip the printer by the foam packing material which may break, causing the printer to drop.
- When opening the cover, open it all the way. If only part way open, the cover could slam shut, possibly causing injury.
- Be careful of the edge of the cover when the cover is opened. It may cause injury or property damage.
- Be careful of the edges of the metal plates so injury or property damage is possible.

## Part Names and Functions

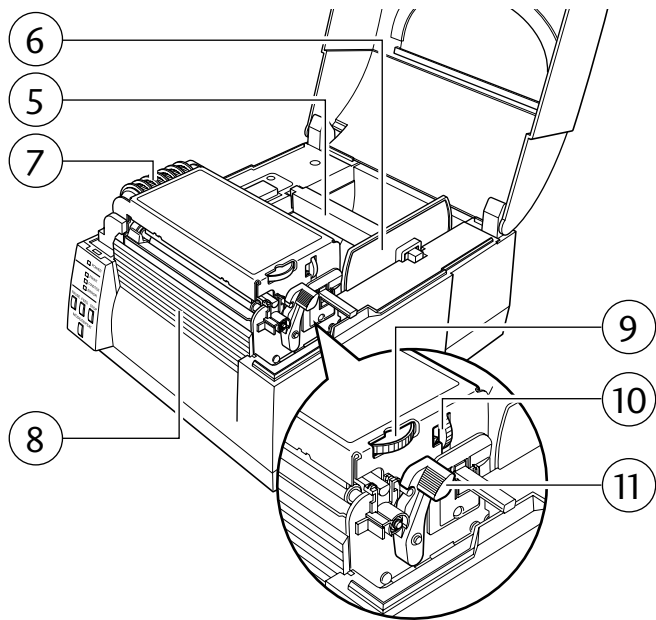

⑤ **Media holder bar**

The media is supported by the media holder bar when installed in the printer.

⑥ **Media holder guide**

This guide is moved horizontally to match the media size.  
The guide can be sliding it from the holder bar.

⑦ **Motor cover**

It discharges the heat of the media feed motor.  
Do not cover it with media etc.

⑧ **Front cover**

It is removed to install optional units such as the peeler or cutter.

⑨ **Media width adjustment dial**

It is adjusted to match the width of the media.

⑩ **Media thickness adjustment dial**

It is adjusted to match the thickness of the media.

⑪ **Large blue-head open lever**

The head unit can be raised to install media by pushing this lever.  
It locks the head unit during printing.

*Media Width Adjustment*  
(p.38)

*Media Thickness Adjustment*  
(p.37)

## Part Names and Functions

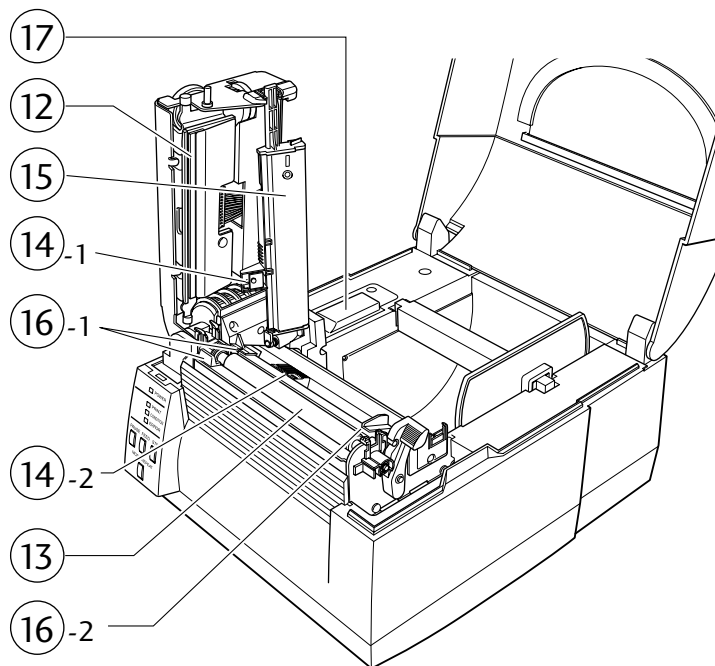
**⑫ Thermal head**

This is the printhead. Avoid touching this with your fingertips and leaving grease or dirt on the printhead surface.

**⑬ Platen**

Interlocked with the thermal head, it feeds media backwards or forwards.

**⑭ Upper sensor (⑭-1) and bottom sensor (⑭-2)**

When used as a transparent sensor (for labels and tags with notches), it is used by matching the sensor markings of the upper sensor and the bottom sensor. When used as a reflective sensor, it is used by matching the sensor marking on the bottom sensor with the position of the black mark on the liner or media backing.

**⑮ Sensor arm**

The media can be installed by raising this arm.  
The media can be held in place by lowering this arm.

**⑯ Media guides (Left fixed media guide (⑯-1) and right movable media guide (⑯-2))**

The end of the media is matched to the left fixed media guide, then the right side movable media guide is moved horizontally to match it to the media size.

**⑰ Optional unit connector cover**

It is opened when the cables of the cutter unit and the peeler unit are connected. Do not remove during normal use.

*Setting sensor positions  
(p.23)*

*Sensor Adjustments (p.34)*

*Media Setting (p.24)*

## Part Names and Functions

## Operation Panel

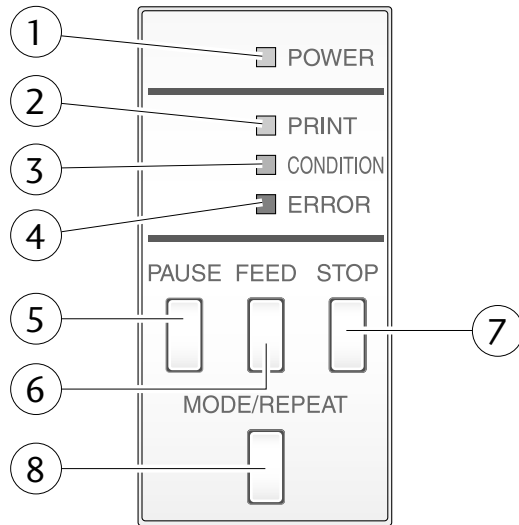

*LED Functions (p.20)*

① **POWER LED**

This is lit when the printer power is on. (green)

② **PRINT LED**

This is lit when the printer is able to print. (green)

③ **CONDITION LED**

This is on when selecting settings. (orange)

④ **ERROR LED**

This is lit or flashes when the printer is in an alarm or error status. (red)

⑤ **PAUSE key**

This temporarily stops printing.

⑥ **FEED key**

This key feeds the media to the top of the next label or form.

⑦ **STOP key**

This stops printing or cancels the alarm.

⑧ **MODE/REPEAT key**

This key exits current status in the menu setting mode or reprints the final label, depending on printer status.

*Normal Operating Mode  
(p.19)*

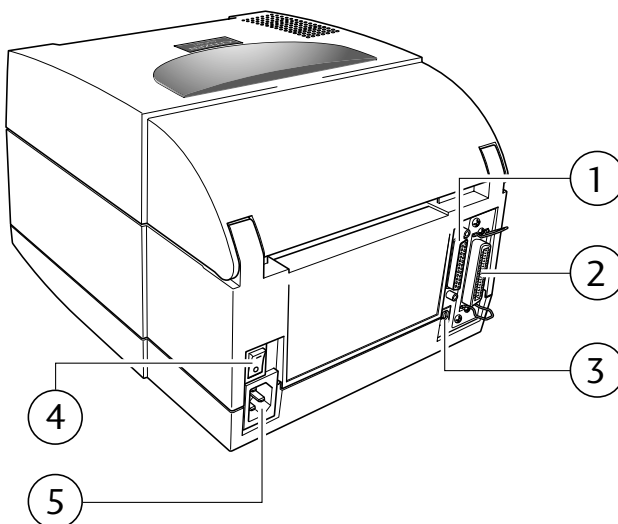
**Rear View**

*Serial interface (p.45)*

① **Serial interface (RS232C)**

This receives serial transmission of data from a host computer.

*Parallel Interface (p.47)*

② **Parallel interface (Centronics parallel or IEEE1284)**

This receives parallel transmission of data from a host computer.

*USB Interface (p.50)*

③ **USB interface**

This receives USB transmission of data from a host computer.

*Power ON/OFF (p.18)*

④ **Power switch**

The is the power switch for the printer.

*Connection to Power (p.16)*

⑤ **Power cord inlet**

The connector of the enclosed power cord is connected here.

## Connection to Power

1. Check that the power switch to the printer is turned OFF.
2. Connect the connector of the power cord to the power cord inlet on the printer.
3. Insert the plug of the power cord in the AC outlet.

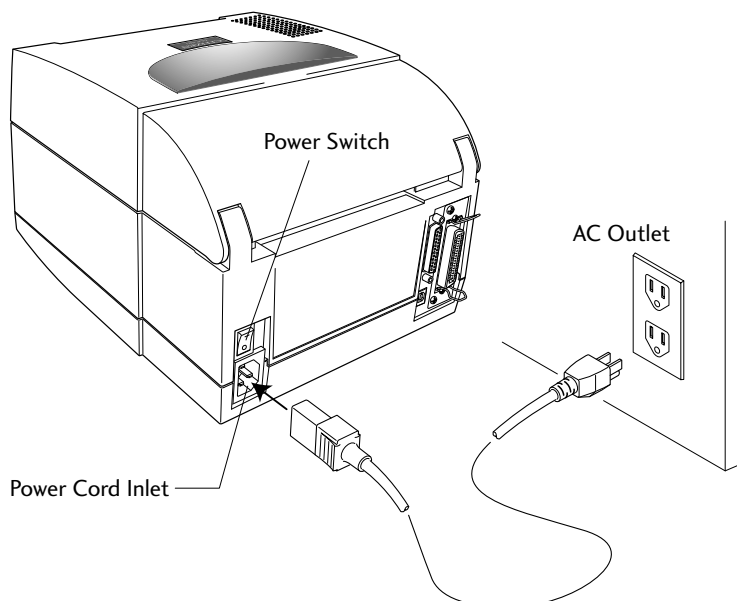

### Caution

Use an AC outlet that accepts a three-pronged plug. Otherwise, static electricity may be generated and there will be danger of electric shock.

## Driver Installation

The computer may automatically detect the presence of the new printer when it is first started, depending on the computer type, interface and operating system. Follow any on-screen instruction and also instructions supplied with any additional CD-ROM or floppy disk included with your printer.

Your supplier will assist you with the correct drivers and software which are compatible with your particular computer system.

## Connection to a Computer

This product has three interfaces that can be used to receive printing data: a serial port (RS232C), parallel port (IEEE1284), and a USB port (USB1.1). An optional internal Ethernet (LAN) or Wireless LAN (WiFi) port can be added by your dealer.

With the exception of a wireless LAN connection, an interface cable is necessary to connect the printer to a computer.

To connect the cable, proceed as follows:

1. Turn OFF both power switches of the printer and the computer.
2. Connect one end of the interface cable to the interface connector on the back of the printer and secure it with locks or locking screws, where available.
3. Connect the other end of the interface cable to the interface connector on the computer and secure it with locks or locking screws, where available.

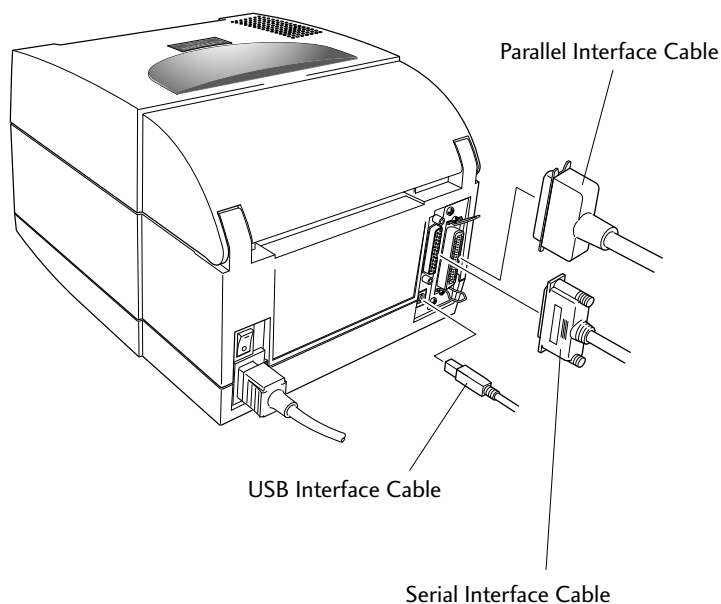

*Serial interface (p.45)*

*Parallel Interface (p.47)*

*USB Interface (p.50)*

*Replacing the Interface Board (p.51)*

**Note:** If the optional Ethernet or wireless LAN port is used, the standard parallel port is removed from the printer, so the parallel interface cannot be used.

## Power ON/OFF

### Turning on the power

1. Turn on the power switch on the back of the printer.
2. The POWER and PRINT LED are lit.

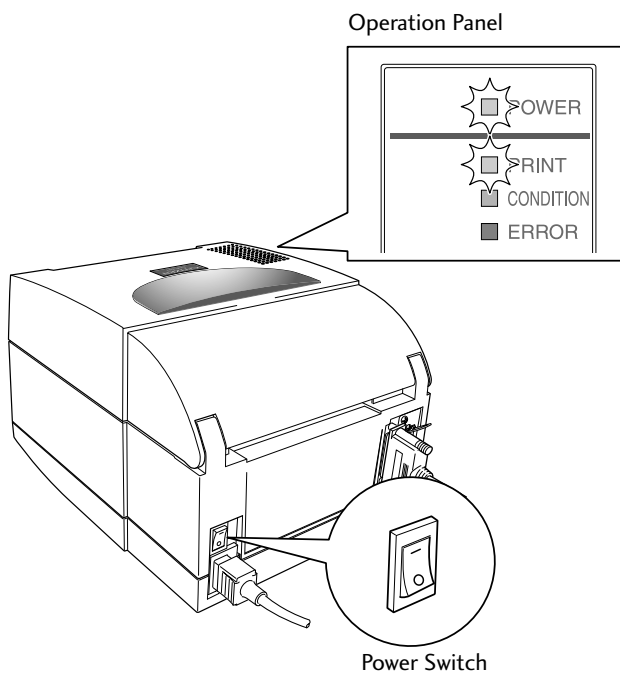

### Turning off the power

1. Turn off the power switch on the back of the printer.
2. The POWER and PRINT LED go off.

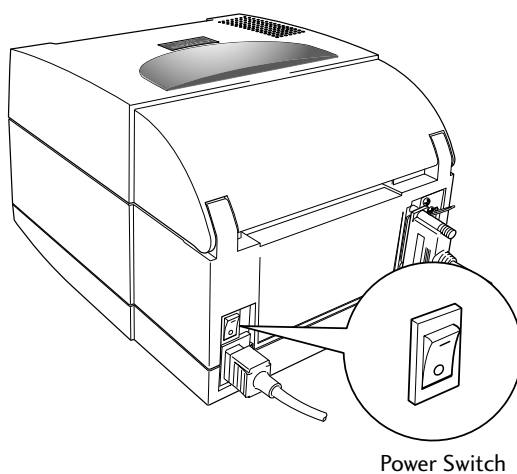

*Menu Setting Mode (p.27)*

## Normal Operating Mode

When the power is turned on, the printer enters normal operating mode. The control keys activate the following functions.

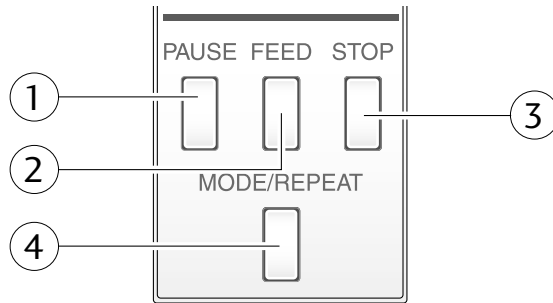

### ① PAUSE key: Temporarily pauses printing

- When this key is pushed once, the PRINT LED turns off and the printer temporarily pauses.
- When it is pushed during printing, the printer pauses after the label currently being printed is issued. Pressing the key a second time restarts printing and the remaining number of designated labels are printed.

### ② FEED key: Feeds media

- Pressing this key feeds media to the print start position. The distance it is fed is determined by automatically detecting the front end of the media when using label media, and when continuous media has been designated, a fixed quantity is fed, then feeding stops.
- When the TEAR OFF setting is effective, feeding stops when the media has been fed to the TEAR OFF location.
- When the optional cutter unit is installed, the media is fed to the cut position then it is cut.  
Regardless of whether there is or is not a cut operation setting on the setting menu, if the unit is installed, the media is cut each time it is fed.
- If the optional peeler unit is installed, the media is fed to the peeling location. When the media is pausing at the peeling position, feeding does not occur, even if the FEED key is pushed.

### ③ STOP key: It stops printing and cancels the alarm

Pushing this key once during printing puts the printer in pause mode after the label is issued. It is possible to cancel 1 batch of label issuing data by pressing the STOP key for 4 seconds or longer in pause status. (The PRINT LED flashes at high speed during cancel.)

### ④ MODE/REPEAT key:

**It reprints the last label when pressed for 4 seconds.**

Pushing the MODE/REPEAT key continuously for 4 seconds in PRINT status (when the PRINT LED is lit) reissues the last label. The last label is issued by setting MODE/REPEAT on the menu.

## Normal Operating Mode

### LED Functions

In addition to normal operating mode, when an abnormal condition is detected in the printer, a buzzer sounds and each LED either lights up or flashes to indicate the type of error.

- ① **POWER LED**  
It lights up when printer power is turned on. (green)
- ② **PRINT LED**  
This is lit when the printer is able to print. (green)
- ③ **CONDITION LED**  
This is on when selecting settings. (orange)
- ④ **ERROR LED**  
This is lit or flashes when the printer is in alarm status. (red)

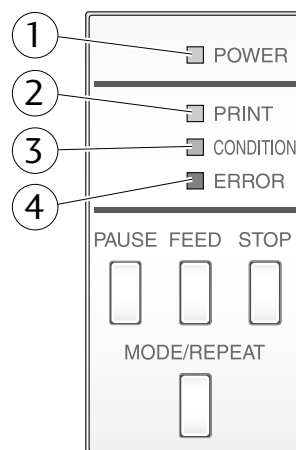

### Table of Warning and Error Indications

Item	PRINT LED	CONDITION LED	ERROR LED
When the STOP key has been pushed	OFF	OFF	OFF
Abnormal head temperature	○ ON ● OFF	○ ON ● OFF	OFF
Abnormal motor temperature	○ ON ● OFF	● OFF ○ ON	OFF
Head open	OFF	OFF	○●○●○●○●
Media end	OFF	OFF	○ ON ● OFF
Media out (media location cannot be detected)	OFF	○ ON ● OFF	○ ON ● OFF
Abnormal head resistance	OFF	○ ON ● OFF	● OFF ○ ON
Communication error (reception buffer overrun)	OFF	○ ON ● OFF	OFF
Communication error (parity, framing)			
Communication error (transmission buffer overflow)			
Auto cutter abnormality (jamming etc.)	OFF	OFF	ON

Time Axis →

○: ON, ●: OFF

Wide on/off marks indicate slow LED flashing.

Small circle on/off marks indicate quick LED flashing.

# Setting the Media

## Media Sizes

The position of label and tag media is sensed by either a transparent sensor or a reflective sensor.

Transparent sensor: Detects the gaps between label media and notches of tag media

Reflective sensor: Detects the black mark

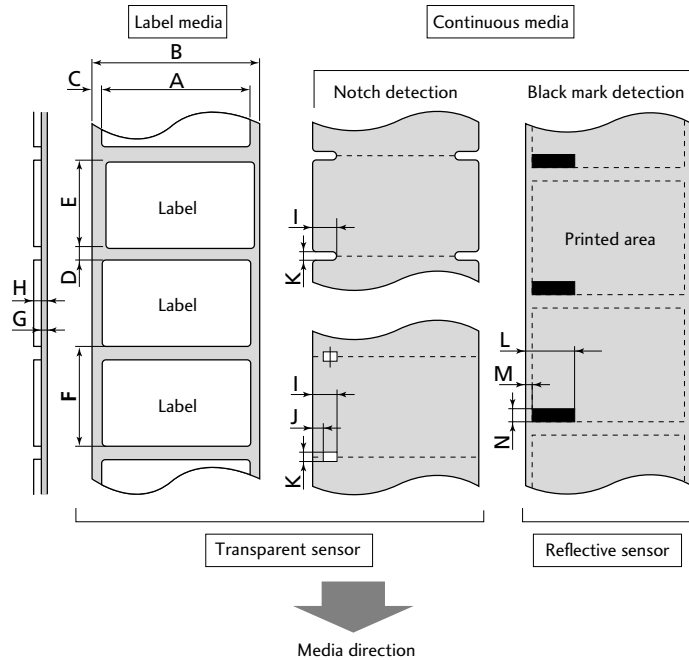

		Min. value mm (inches)	Max. value mm (inches)
A	Label width	19.50 (0.77)	118.00 (4.65)
B	Liner width	19.50 (0.77)	118.00 (4.65)
C	Label left edge position	0 (0)	2.54 (0.10)
D	Length of gap between labels	2.54 (0.10)	812.8 (32.00)
E	Label length	6.35 (0.25)	812.8 (32.00)
F	Label pitch	6.35 (0.25)	812.8 (32.00)
G	Liner thickness	0.06 (0.0025)	0.125 (0.0049)
H	Total media thickness	0.06 (0.0025)	0.25 (0.01)
I	Position of right edge of notch	3.60 (0.14)	60.80 (2.39)
J	Position of left edge of notch	0 (0)	57.20 (2.25)
K	Notch length	2.54 (0.10)	17.80 (0.70)
L	Right edge of black mark	15.00 (0.59)	66.50 (2.62)
M	Left edge of black mark	0 (0)	51.5 (2.02)
N	Black mark width	3.18 (0.125)	17.80 (0.70)

\* Use a transparent sensor for label media gaps and media with black marks.

\* Use a transparent sensor for fan fold media.

\* If the label pitch is 1 inch or less, set the Small Media Adjustment menu to ON and match it to the label that uses the value of the Small Media Length menu.

Menu Setting Table (p.32)

## Setting the Media

### Installing the Media

1. Push the large blue-head open lever to release the head unit and sensor arm. It can be opened to the position shown below by lifting the head unit by hand.

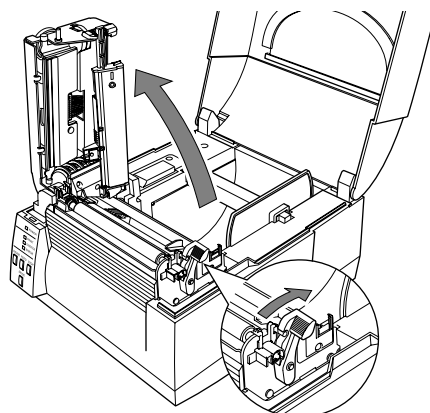

Large blue-head open lever

2. Firstly, slide the two black plastic parts of the media holder assembly together. Ensure correct alignment of the guide with the bar as it can only be installed in one direction.
3. Slide the roll of media over the media bar. The media guide must be on the right side of the roll of media (as viewed from the front of the printer) with the flat surface of the media guide touching the roll.

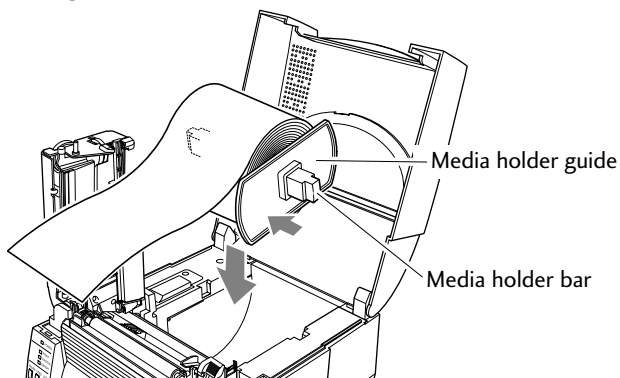

*Media Sizes (p.21)*

4. Set the media roll and media holder in to the printer as shown above. It is advisable to pull a length of media forwards and through the mechanism ready for later positioning.
5. Move the media roll so it is touching the leftside of the housing. Then slide the black media guide so it is touching the media on the right side. Do not try to hold the media too tightly with these guides as it will cause the printer to jam during printing.

*Sensor Selection Method  
(Transparent ↔ Reflective)  
(p.34)*

*Adjusting the Transparent  
sensor (p.35)*

**6. Setting sensor positions.**

**When using a transparent sensor**

Move the bottom sensor close to the center of the width of the media then align the upper sensor marker and the bottom sensor marker.

When using media that is 4 inches wide, position the upper sensor and the bottom sensor all the way to the right (head open lever side).

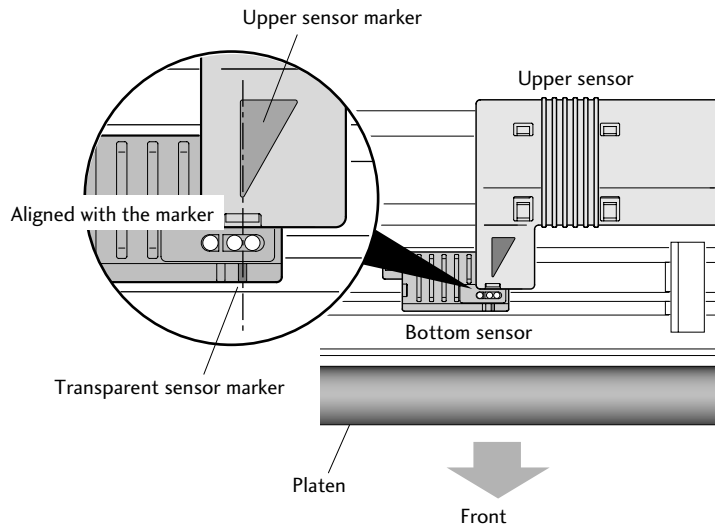

*Adjusting the Reflective  
sensor (p.36)*

**When using a reflective sensor**

Adjust the position of the sensor so that the reflective sensor marker of the bottom sensor is at the center of the black mark of the media as shown below.

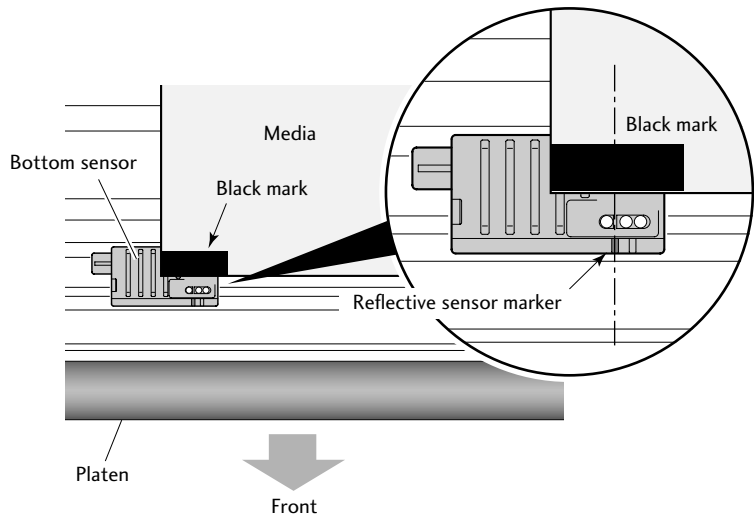

## Setting the Media

- Align the media with the left fixed media guide (2 locations), align the right movable media guide with the media width, and lower the sensor arm.

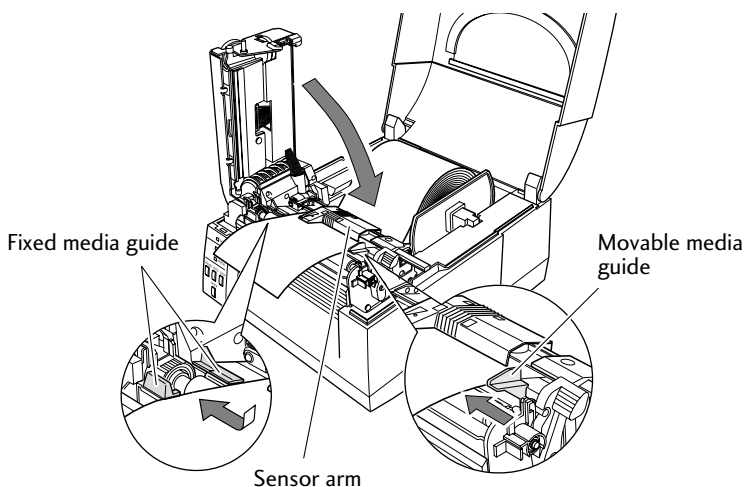

*Media thickness Adjustment*  
(p.37)

*Media Width Adjustment*  
(p.38)

- Lower and lock the head unit. Align it with the width of the media that has been set, then set the media width and media thickness adjustment dials. See "Chapter 3 Printer Adjustments".

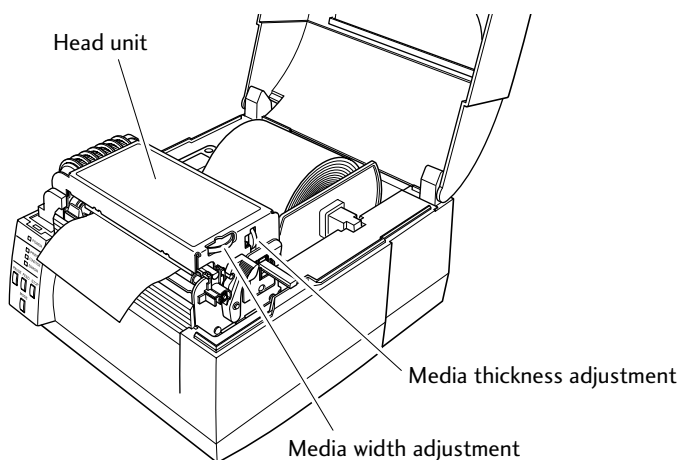

- With the power switched on, push the FEED key to feed the media. It will halt at the next print start position.

Operation Panel (P.14)

## Mode Settings

Turning on the power while pressing keys in the following combinations starts various functions.

Mode	Key operation
HEX dump mode	Turning power on while pushing the STOP key.
Self print mode	Turning power on while pushing the FEED key.
Menu setting mode	Turning power on while pushing the MODE/REPEAT key.

### HEX Dump Mode

- **When using label media**

Turn on printer power while pushing the STOP key. If the PRINT LED has begun to flash slowly, release the STOP key, and then the printer enters HEX DUMP mode.

- **When using continuous media**

Turn on printer power while pushing the STOP key. If the PRINT LED has stopped flashing slowly and begun to flash rapidly, release the STOP key, and then the printer enters HEX dump mode.

```

DUMP LIST
02 40 30 31 30 30 0D 02 60 30 30 32 30 0D 02 4C .M0100..c0020..L
44 31 31 0D 31 30 30 30 30 30 30 30 30 30 31 30 D11.100000000010
30 30 31 30 31 32 33 34 35 36 37 38 39 3A 3B 3C 0010123456789:;<
    
```

*DUMP LIST*

## Mode Settings

*Setting the Media (P.21)*

### Self Print Mode

Performing a self test print is an easy way to check on the state of printer setting and printing quality. Install the media as explained in “Installing the Media” and then operate the printer as follows.

- **Case of label media**

Turn on printer power while pushing the FEED key. When the PRINT LED has begun to flash slowly, release the FEED key. After it enters TEST MODE and media has fed, two labels print then printing stops.

To restart printing, press the FEED key once more.

- **Case of continuous media**

Turn on printer power while pushing the FEED key. When the PRINT LED has stopped flashing slowly and has begun to flash rapidly, release the FEED key. After it enters TEST MODE and it prints then printing stops.

To restart printing, press the FEED key once more.

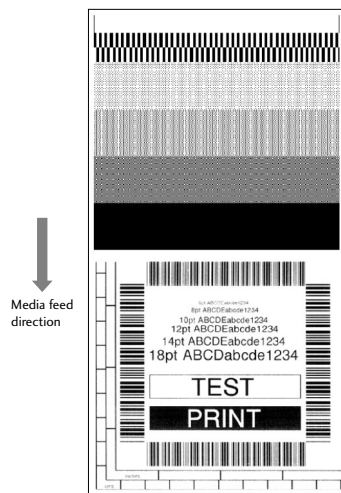

*Self print pattern*

### Media Adjustments

Using the Self Test Print shown above, you can make adjustments to the printer settings such as media width and media thickness (printhead pressure). The location of these two adjustments is explained in Chapter 3.

*Media thickness Adjustment (p.37)*

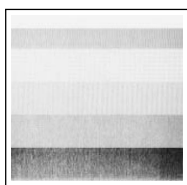

The first sample, left, shows an incorrectly set “media thickness adjustment”. For standard label media, it is recommended you set the blue dial to the “0” position.

*Media Width Adjustment (p.38)*

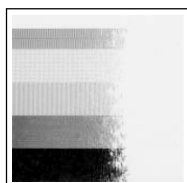

The second sample, left, shows an incorrectly set “media width adjustment”. For 4-inch or 100mm wide media, the adjuster should be set to the “9” position on the blue dial.

The settings shown above are for general label media and may not apply to specialist media.

### Menu Setup Mode

If the printer power is turned on while the MODE/REPEAT key is pressed, the printer enters menu setup mode. In this mode, the printer's configuration can be changed using the VuePrint Menu System. During menu setting mode, the PRINT LED and CONDITION LED are on. Media must be installed in the printer to use the VuePrint menu system.

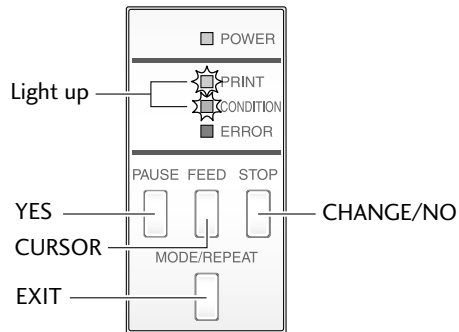

### Functions of the keys

After each menu item is printed, the printer will also print the function of each of the buttons at that time. They vary slightly depending on the menu selected but generally fit the following guidelines:

#### PAUSE key (YES):

It is pushed to either select the current menu option or to save the new setting after which it advances to the next menu.

#### STOP key (CHANGE/NO):

Whilst changing a menu value (such as head temperature), pressing this key displays the next menu value available but does not save the setting. In the "main menu", pressing this key moves to the next menu available.

#### FEED key (CURSOR):

With some menu options such as head temperature, there is more than one "digit" than can be changed. This key moves the cursor to the next digit.

#### MODE/REPEAT key (EXIT):

Exits the current menu or the VuePrint menu system.

### Caution

When you are changing a menu value, pressing the "PAUSE" key (YES) causes the printer to save the currently selected parameter. The CONDITION LED flashes briefly. Do not turn off the power to the printer at this time as this may cause a malfunction. If the power is accidentally turned off, first reset the printer to factory defaults.



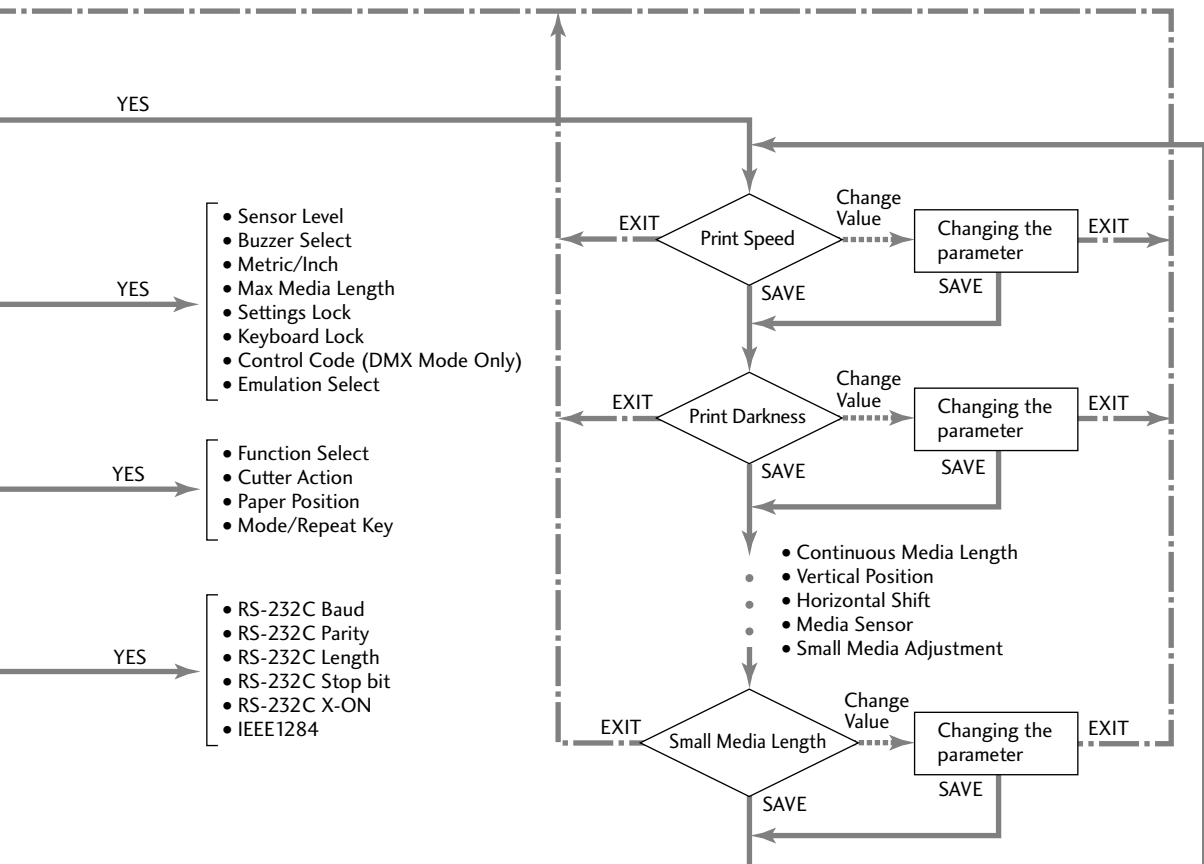
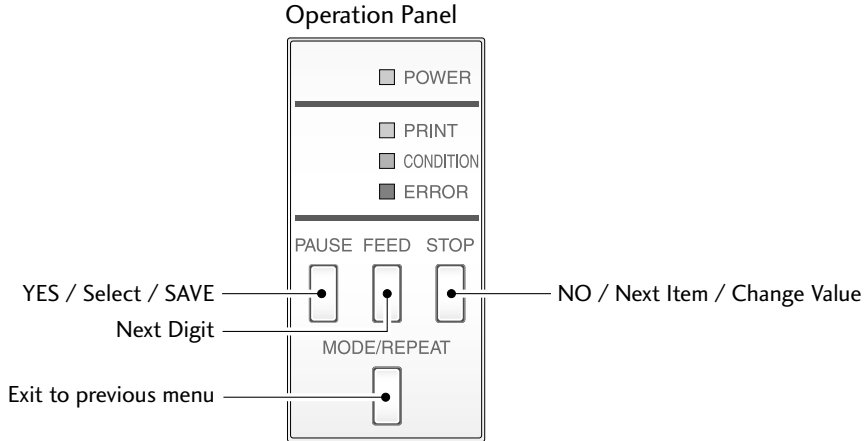

## Mode Settings

Menu Setting Flow Chart (p.28)

Menu Setting Flow Chart (p.28)

Shown below is a sample menu output from the CLP-521 VuePrint menu system.

This particular example is changing the print speed and print darkness then continues through the remainder of the "Print Setup" menu.

The actual output from the printer is "vertically reversed" due to the way the printer outputs the menu options. Please look at the example below to see how the output changes.

### Example of printing during top menu setting

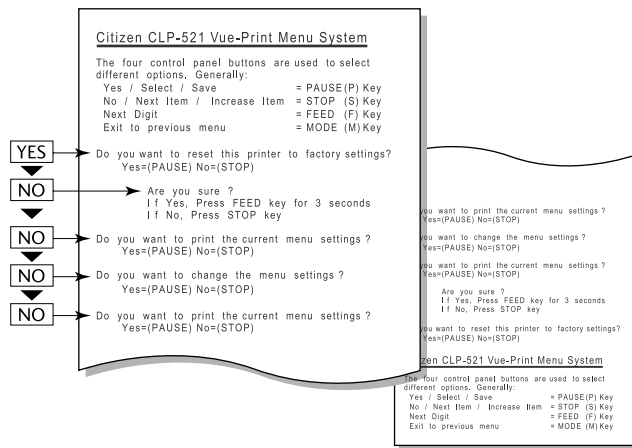

### Example of printing during sub menu setting

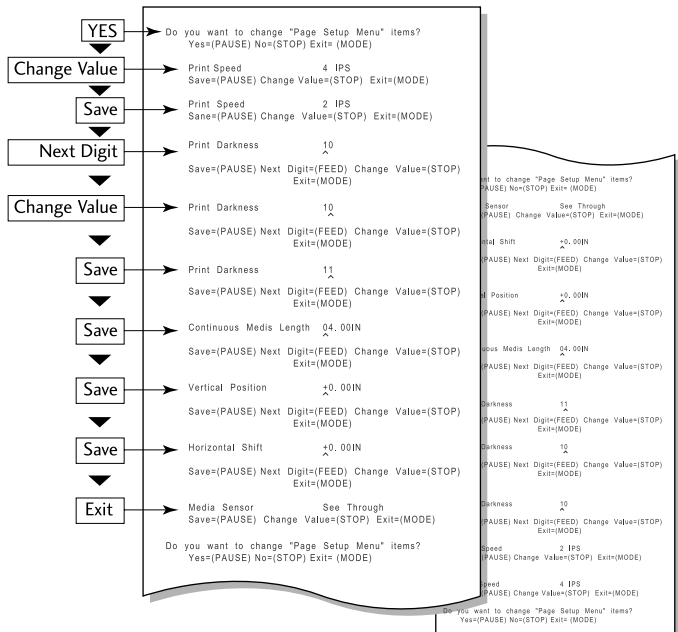

Menu Setting Flow Chart  
(p.28)

### Example of printing of contents of settings

#### Machine Information

Model Number	:	CLP-521
Boot Version	:	X. X
ROM Version	:	CM00XXXX
ROM Date (DD/MM/YY)	:	XX/XX/XX
ROM Check Sum	:	XXXX
Head Check	:	OK
Print Counter	:	76. 9 m
Service Counter	:	3. 8 m
Sensor Monitor	:	2. 20 V
Option Interface	:	None

#### Current Menu Settings

##### [Page Setup Menu]

Print Speed	:	4 IPS
Print Darkness	:	10
Print Method	:	Direct Thermal
Continuous Media Length	:	4. 00 inch
Vertical Position	:	0. 00 inch
Horizontal Shift	:	0. 00 inch
Media Sensor	:	See Through
Small Media Adjustment	:	Off
Small Media Length	:	1. 00 inch

##### [System Setup Menu]

Sensor Level	:	1. 5 V
Buzzer Select	:	On
Metric/Inch	:	Inch
Max Media Length	:	10. 00 inch
Setting Lock	:	Off
Keyboard Lock	:	Off
Control Code	:	STD
Emulation Select	:	DM4

##### [After Print Menu]

Function Select	:	Off
Cutter Action	:	Backfeed
Paper Position	:	0. 00 inch
Mode/Repeat Key	:	Disabled

##### [Interface Menu]

RS-232C Baud rate	:	115200 bps
RS-232C Parity	:	None
RS-232C Length	:	8 bit
RS-232C Stop bit	:	1 bit
RS-232C X-ON	:	Yes
IEEE 1284	:	On

**Note:** Citizen continually enhances its printers with new options and settings based on our customer's requests. Extra or changed menu items may appear on the above print out in some case.

## Mode Settings

### Menu Setting Table

**Page Setup Menu** - allows you to change settings related to the media or print quality.

**System Setup Menu** - allows you to change settings for the printer hardware and basic control systems.

**After Print Menu** - changes how the printer reacts after the label has been printed.

**Interfaces** - changes interface parameters such as baud rate.

### Menu Setting

Top Menu	Sub Menu	Default	Menu	Remarks
*Page Setup	Print Speed	4 IPS	2 to 4 IPS	Printing speed setting
	Print Darkness	10	00 to 30	Print darkness setting (printhead temperature)
	Continuous Media Length	4.00 IN 101.6mm	0.25 to 32.00 IN 6.35 to 812.8mm	Setting default length of continuous media, if selected.
	Vertical Position	0.00 IN 0.0mm	-1.00 to 1.00 IN -25.4 to 25.4mm	Print start position adjustment; the lower line is in metric mode.
	Horizontal Shift	0.00 IN 0.0mm	-1.00 to 1.00 IN 25.4 to 25.4mm	Horizontal printing location adjustment
	Media Sensor	See Through	See Through Reflect None	Label sensor selection
	Small Media Adjustment	OFF	ON OFF	Setting for small labels
	Small Media Length	1.00 IN 25.4mm	0.25 to 1.00 IN 6.35 to 25.4mm	Setting length of small label media
*System Setup	Sensor Level	1.5V	0.0V to 3.3V	Setting the threshold of the sensor
	Buzzer Select	ON	ON OFF	Setting buzzer sounding conditions
	Metric/Inch	Inch	Inch mm	Setting the units used
	Max Media Length	10.00 IN 254.0mm	1.00 to 50.00 IN 25.4 to 1270.0mm	Setting the maximum label length
	Settings Lock	Off	On/Off	When on, prevents software commands from changing the values set by the VuePrint menu
	Keyboard Lock	Off	On/Off	Prevents the control panel from affecting the printer's configuration. (User "lock-out")
	Control Code (DMX Mode Only)	STD	STD/ALT	Uses the command instead of STX in DMX mode. Sometimes called "AS400 emulation"
	Emulation Select	DM4	DMI DM4 DPP	Datamax compatibility selection DMI DataMax IClass DM4 DataMax 430 like DPP DataMax Prodigy Plus

## Mode Settings

Top Menu	Sub Menu	Default	Menu	Remarks
* After Print	Function Select	Off	Off Tear Peel On Cutter Standard	Selects the type of options installed and adjusts the "paper stop" position accordingly. For example, the position where the label stops in "Tear" mode is different to that in "Peel On" mode.
	Cutter Action	Backfeed	Backfeed Through	Cutter operating method setting Backfeed: it feeds back after each cutting operation. Through: when the number copied = n, the back end of sheet 1 to n-1 passes through, and the back end of the final page that is a single sheet is copied and fed back.
	Paper Position	0.00IN 0.00mm	Peel/Cut/Tear Off 0.00 to 2.00 IN 0.0 to 50.8mm Peel/Cut/Tear On -1.00 to 1.00 IN -25.4 to 25.4mm	The stop position can be fine tuned using this menu setting. The general stop position is selected depending on the "Function" selected above.
	Mode/Repeat Key	Disabled	LabelSet LastOne Disabled	Repeat method selection LabelSet: Reissues multiple labels. LastOne: Issues only the final page. In count case, it issues only 1 label while continuing. Disabled: Makes the repeat key invalid.
* Interface	RS-232C Baud	115200	115200 57600 38400 19200 9600 4800 2400	Sets the baud rate of the serial interface. • Interface related settings are effective after the power is turned on again.
	RS-232C Parity	None	None Odd Even	Sets the communication parity of the serial interface.
	RS-232C Length	8 bits	8 bits 7 bits	Sets the character length of the serial interface.
	RS-232C Stop bit	1 bit	1 bit 2 bits	Sets the stop bit of the serial interface.
	RS-232C X-ON	Yes	Yes No	Selects the X-ON flow control of the serial interface.
	IEEE1284	ON	ON OFF	Enable or disables the 'enhanced' features of the IEEE1284 parallel interface.

# 3 Printer Adjustments

## Sensor Adjustments

The sensing level of both the transparent (see thru) and reflective sensors is adjusted separately and independently. Firstly, the sensor type must be selected either using the VuePrint menu system or the Sensor Method Selection shown below. Then the adjustment and calibration of the sensor can be made.

### Entering Sensor Adjustment Mode

1. Turn on the power while pushing the PAUSE key, FEED key, and STOP key simultaneously.

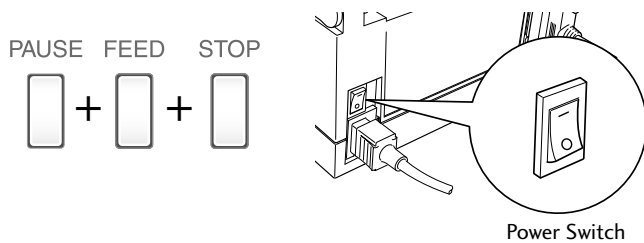

2. After the PRINT LED and CONDITION LED light up, release the keys to change the printer to sensor adjustment setting mode.

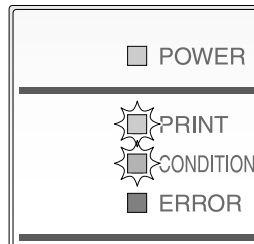

*Media Setting (p.23)*

### Sensor Selection Method (Transparent ↔ Reflective)

To switch from transparent to reflective sensor, ensure the CONDITION LED is lit then hold down the MODE/REPEAT key and then press the STOP key. Each time you press the STOP key, you switch to back and forth between the two sensor types.

If the transparent sensor is selected, the PRINT LED lights up and the buzzer sounds once. If the reflective sensor is selected, the PRINT LED flashes slowly and the buzzer sounds twice.

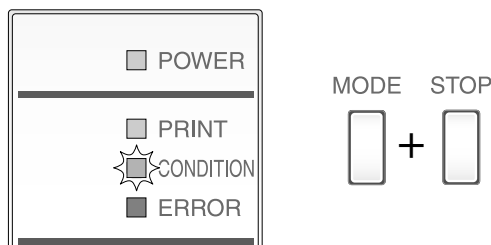

Media Setting (p.23)

Sensor Selection Method  
(Transparent ↔ Reflective)  
(p.34)

### Adjusting the Transparent sensor

1. Open the printhead and close the sensor arm, then align the positions of the markers on the upper sensor and the bottom sensor.

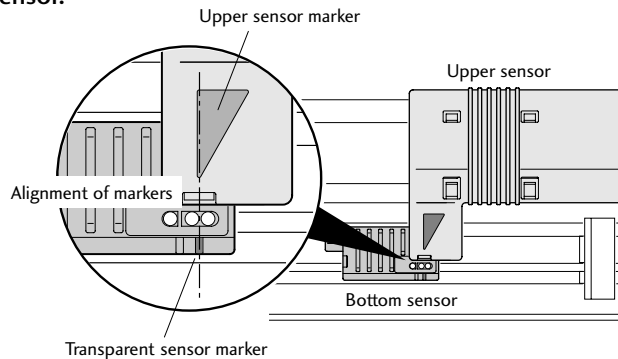

2. Select the transparent sensor, and open the sensor arm.
3. Install only the liner media (label backing paper) with the label media removed so that it will pass between the platen roller and the media sensor. (Be careful that media with black marks does not pass the media sensor.) Then close the sensor arm and the printhead.

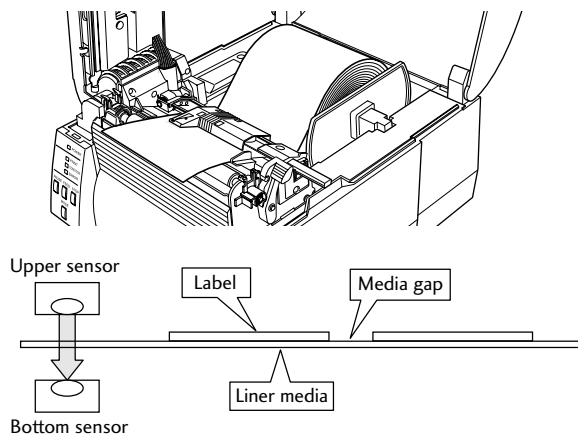

4. If the PAUSE key is pushed while the MODE/REPEAT key is pressed, the PRINT LED goes off, after the CONDITION LED switches from lit to rapid flashing, media feeding starts, and the sensor is automatically adjusted.
5. If automatic adjustment stops normally, the PRINT LED and CONDITION LED return to their original status. If it stops abnormally (adjustment impossible), the CONDITION LED and ERROR LED flash.
6. If the STOP key is pushed, it exits sensor adjustment mode.

## Sensor Adjustments

### Adjusting the Reflective sensor

1. Open the printhead and the sensor arm, then align the position of the sensor marker of the bottom sensor is at the center of the black mark on the media.

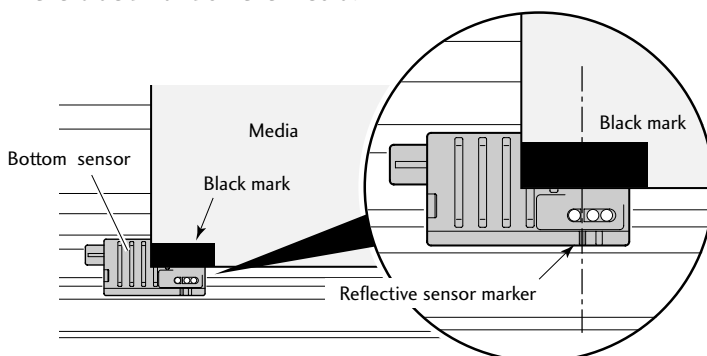

*Sensor Selection Method  
(Transparent ↔ Reflective)  
(p.34)*

2. Select the reflective sensor.
3. With the reflective sensor selected, install the label media so that it is between the platen roller and the media sensor. (Be careful that black mark and media gap do not pass the media sensor.) Then close the sensor arm and the printhead.

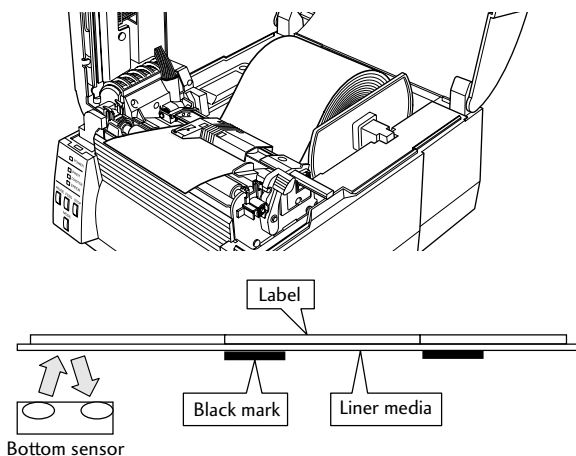

4. If the PAUSE key is pushed while the MODE/REPEAT key is pressed, PRINT LED goes off, the CONDITION LED switches from lit to rapid flashing, media feeding starts, and the sensor is automatically adjusted.
5. If automatic adjustment stops normally, the PRINT LED and CONDITION LED return to their original status. If it does not stop normally (adjustment impossible), the CONDITION LED and ERROR LED flash.
6. If the STOP key is pushed, it exits sensor adjustment mode.

## Media Thickness Adjustment

It is necessary to perform offset adjustment because the head offset varies according to the type of media. The printer can be adjusted easily by rotating the media thickness adjustment dial. If the print quality is poor, adjust the printer with the media thickness adjustment dial.

- **Head Offset**

Align the positions of the head and the center of the platen roller to obtain the highest quality printing.

### When using standard label media, high quality media or thermal paper

Adjust while performing test printing by turning the dial from the smallest number on the dial to the largest number on the dial one step at a time.

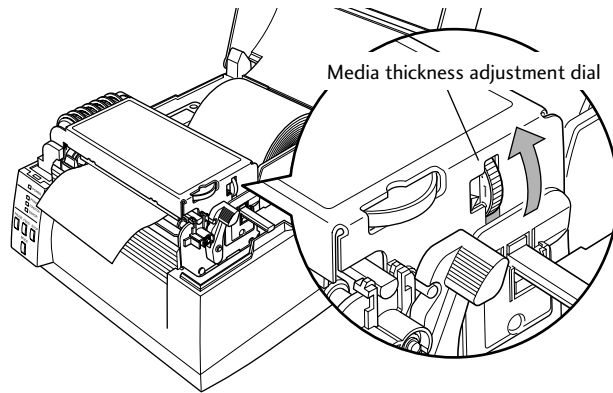

### When using thicker media (tags, card, etc.)

Adjust while performing test printing by turning the dial from the smallest number on the dial to the largest number on the dial one step at a time.

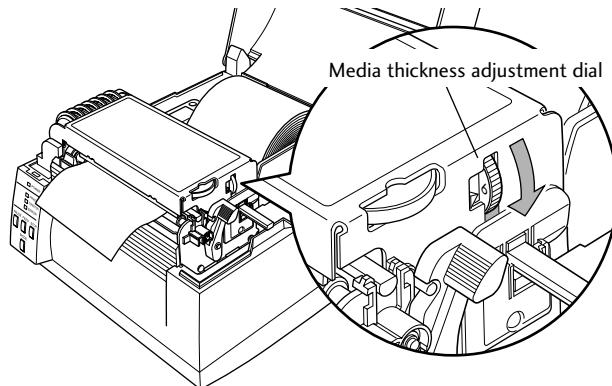

- When shipped from the factory, it is set at dial 1.
- The offset adjustment varies according to the thickness and the hardness of the media.

Media Setting (p.22)

## Media Width Adjustment

The head pressure varies according to the width of the media being printed. The head pressure balance must be adjusted according to media width so that constant head pressure is applied to the head. With this printer, it can be adjusted easily by turning the media width adjustment dial.

If the printing is blurred or lightly printed on one side or the media moves in a zigzag pattern adjust the head pressure balance.

### Caution

When using narrow media, be sure to do this adjustment. (If you do not, the head may be damaged by jamming, etc.)

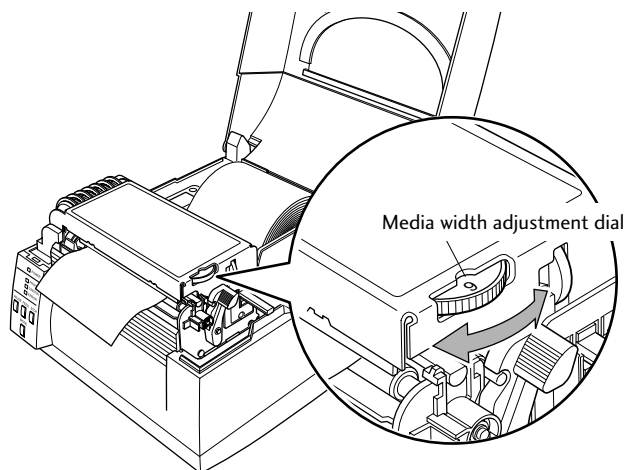

Dial position	Media width mm (inches)	Head pressure
0	19.5 to 23.0mm (0.77 to 0.90)	 Low High
1	23.0 to 30.0mm (0.90 to 1.18)	
2	30.0 to 39.0mm (1.18 to 1.53)	
3	39.0 to 49.0mm (1.53 to 1.92)	
4	49.0 to 62.0mm (1.92 to 2.44)	
5	62.0 to 76.0mm (2.44 to 2.99)	
6	76.0 to 88.0mm (2.99 to 3.46)	
7	88.0 to 99.0mm (3.46 to 3.89)	
8	99.0 to 108mm (3.89 to 4.25)	
9	108 to 118mm (4.25 to 4.65) (setting when shipped)	

The following values are criteria.

## Cleaning

Wipe off any foreign matter such as media dust, dirt and adhesive substances built up around the printhead with the head cleaning pen (head cleaner) provided, and use a soft cloth soaked in ethyl alcohol for the platen etc. It is particularly important to clean the printhead after printing on thermal media for long periods, which will guarantee the print quality and extend the life of the printhead.

Note: Always use the head cleaner when cleaning the printhead.

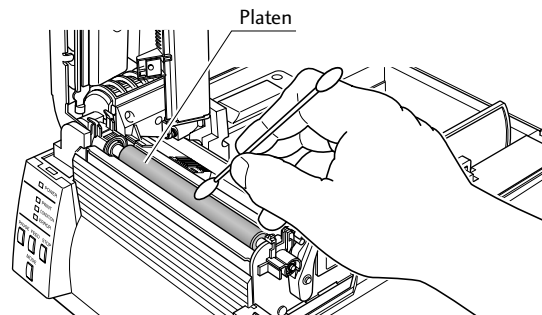
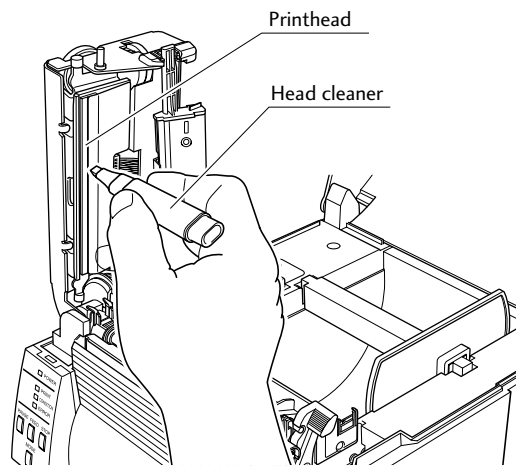

### Caution

Do not use any solvent other than ethyl alcohol. Solvents such as benzene, acetone and thinner will dissolve plastic parts and destroy the printhead, platen and much of the printer!

# 4 Troubleshooting

This chapter explains corrective actions taken when the printer malfunctions or when an error message is displayed.

## Items to check when a malfunction occurs

When the printer malfunctions during operation, take corrective action with reference to the following table. If the corrective action does not solve the problem, consult with the service personnel at the dealer where you purchased the printer.

*Connection to Power*  
(p.16)

Indication	Check	Corrective action
The LED do not light up when printer power is connected.	1) Is the plug of the power cord correctly inserted into the electric outlet?	1) Insert the plug of the power cord correctly in the electric outlet.
	2) Is the connector of the power cord correctly inserted into the power inlet of the printer?	2) Insert the connector of the power cord correctly into the power inlet of the printer.
	3) Is the power cord damaged?	3) Replace the power cord. Consult with the dealer where the printer was purchased to make sure you obtain a cord made especially for the printer. Note: Do not use any power cord except one made especially for the printer.
	4) Is power supplied to the electric outlet the printer is connected to?	4) Check to make sure power is supplied to the outlet. If there are any problems, make sure power is supplied to the building. Or find out if a power failure has occurred.
	5) Is the main fuse in the building's fuse box burnt out?	5) If necessary, replace the main fuse in the building's fuse box, and reset the main breaker. Ask a qualified serviceman to carry out the replacement.
Paper is feeding, but nothing is printed.	1) Is the print head dirty? Is a label stuck to the head?	1) If it is dirty, remove the dirt with the attached head cleaner. If a label is stuck to the head remove it. Note: Do not use a metal object to remove a label stuck to the inside of the printer. (This may damage the print head.) If adhesive label material is stuck to the print head, remove it with a soft cloth soaked in ethyl alcohol.
The printer is not printing neatly.	1) Is the printing density too high or too low?	1) Set the appropriate printing density using the menu or control software.
	2) Is the platen dirty? Is it deformed?	2) If it is dirty, clean it with ethyl alcohol. If it is deformed, replace it. Note: Consult with the dealer that supplied the printer concerning the replacement.

*Cleaning* (p.39)

*Menu Setting Table*  
(p.32)

*Cleaning (p.39)*

*Media Thickness Adjustment (p.37)*

*Media Width Adjustment (p.38)*

*Media Setting (p.22)*

*Cleaning (p.39)*

*LED Functions (p.20)*

*Menu Setting Table (p.32)*

Indication	Check	Corrective action
The printer is not printing neatly.	3) Is the print head dirty? Is a label stuck to the head.	3) If it is dirty, remove the dirt with the attached head cleaner. If a label is stuck to the head, remove it. Note: Do not use a metal object to remove a label stuck to the inside of the printer. (This may damage the print head.) If adhesive label material is stuck to the print head, remove it with a soft cloth soaked in ethyl alcohol.
	4) Is the print head in the correct position for the media that is used?	4) Adjust the offset of the print head with the media thickness adjustment dial.
	5) Is the printer's head pressure balance correct for the width of the media that is used?	5) Adjust the print head pressure with the media width adjustment dial.
The printing position changes.	1) Is the media properly installed?	1) Correctly install the media.
	2) Is the platen dirty? Is it deformed?	2) If it is dirty, clean it with ethyl alcohol. If it is deformed, replace it. Note: Consult with the dealer that supplied the printer concerning the replacement.
	3) Are the data contents and the command signals from the host appropriate?	3) If an error message is displayed, check the content of the software and the communication status set by the host computer.
	4) Are the menu values set appropriately?	4) Set the correct menu values using the operating panel or the host computer.
	5) Are the sensitivities of the media sensors appropriate for the media that is used?	5) Set the media sensitivity to appropriate values. If this does not solve the problem, change the "Sensor level" that is set in the "System setup."

# Appendixes

## Specifications

Item	Description			
Printing	Printing method	Thermal transfer		
	Resolution	Main scanning line density: 203 dots/inch (8 dots/mm)		
		Sub- scanning line density: 203 dots/inch (8 dots/mm)		
		Head 864 dots (effective dots: 832 dots)		
	Max. print width	104 mm	4.1 inch	
	Max. print length	812.8 mm	32 inch	
	Print density	Print density is adjustable with software		
Printing speed	Printing speed setting	4, 3 or 2 inches per second.		
Print mode	Batch mode	Normal printing (single or multiple sheets)		
	Tear off mode	Feeds back media to the tear-off position after printing is completed.		
	Cut mode *1	Prints while cutting at designated sheet units. The following two kinds of cut mode operations are done.		
		<ul style="list-style-type: none"> <li>• Backfeed</li> <li>• Cut through</li> </ul> (Cut through refers to stopping present printing to cut the previous label when it reaches the cut position. After cutting, printing restarts but a gap may be created at the seam of the printing at this time.)		
	Peel mode*2	Peels labels from the liners after printing them.		
Media	Types of media	Roll, fanfold (continuous media, die-cuts, continuous tags, paper or tickets)		
	Kinds of media	Thermal-transfer media		
	Recommended media	Heat-transfer media: label media (140LAB Ricoh) tag media (TB2EOV, Mitsubishi Paper)		
	Max. media width	118.0 mm	4.65 inch	
	Min. media width	19.5 mm	0.77 inch	
	Min. label width	19.5 mm	0.77 inch	
	Min. label pitch	6.35 mm	0.25 inch	
	Max. media thickness	0.254 mm	0.01 inch	
	Max. media length	812.8 mm	32 inch	
	Min. media length	6.35 mm	0.25 inch	
	Min. media thickness	0.0635 mm	0.0025 inch	
	On-board roll media diameter	Max. external diameter: 127mm	5 inch	
		Media core: 25.4 to 76mm	1 to 3 inch	
	Bar code	One-dimension	<ul style="list-style-type: none"> <li>• Code3 of 9 • UPC-A • UPC-E • EAN-13 (JAN-13)</li> <li>• EAN-8 (JAN-8) • Interleaved 2 of 5 • CODE128</li> <li>• HIBC (Modulus43-used code3 o f9) • CODABAR(NW-7)</li> <li>• Int2 of 5 (Modulus10-used Interleaved 2 of 5) • Plessey</li> <li>• CASE CODE • UPC2DIG ADD • UPC5DIG ADD</li> <li>• Code 93 • Telepen • ZIP • UCC/EAN128</li> <li>• UCC/EAN128 (for K-MART)</li> <li>• UCC/EAN128 Random Weight • FIM</li> </ul>	
Two-dimension		UPS Maxi Code, PDF-417, Data Matrix, QRCode		

Item	Description	
Font	1. Seven kinds of fixed pitch font <ul style="list-style-type: none"> <li>• Overseas, English fonts and European fonts</li> </ul> 2. OCR fonts OCR-A, OCR-B           3. Proportional fonts <ul style="list-style-type: none"> <li>CG Triumvirate smooth font</li> <li>(6, 8, 10, 12, 14, 18, 24, 30, 36, 48, 72 points)</li> <li>• Character set: Conforms with code page 840 standards</li> </ul> 4. True type TM rasterizer *3	
Control language	Conforms to Datamax® programming language *4	
Outline of electronic devices	CPU	32Bit RISC CPU
	ROM	Standard equipment: FLASH ROM 2Mbyte
	RAM	Standard equipment: SDRAM 8MByte
Media detection sensors	Transparent sensor	Detects media gap between labels, notches on tags, and media out
	Reflective sensor	Detects reflective mark on back of media and media out
	Label peeling sensor *1	
Communication interfaces	Parallel	IEEE1284 (compatible, Nibble, ECP mode)
	Serial	2400 4800 9600 19200 38400 57600 115200bps
	USB	FULL Speed USB1.1
Communication interface options	Network	LAN and wireless LAN interface
Indications and switches	LED	POWER, PRINT, CONDITION, ERROR
	Buzzer	Alarms, warnings, etc.
	Operating panel keys	PAUSE, FEED, STOP, MODE/REPEAT
	Head-up detection switch	Detects head open
	Power switch	Turns power on and off
Power (standards)	100V version	100V, 50/60Hz (Japan) 120V (-10%+6%), 2.5A, 60Hz (U.S.A., Canada) UL 1950, CSA No. 950, FCC Part 15 Subpart B (Class A)
	220V version	220V-240V (-10%+6%), 1.2A, 50/60Hz (Europe) EN 60950, EN 55022 (Class A), EN55024, EN61000-3-2, EN 61000-3-3

# Appendixes

## Specifications

Item	Description	
Environment	Operating temperature conditions:	Operating temp. 0 to 40°C, humidity 30 to 80%, condensation free (Conditions: ventilation, and natural convection)
	Storage temperature conditions	Temp. -20 to 60°C, humidity 5 to 85% (Conditions: ventilation, and natural convection)
	<p>Operating assurance temperature Printing assurance temperature</p> <p>Humidity %</p> <p>Temperature °C</p> <p>Conditions assuring operation and printing</p> <p>Storage assurance temperature</p>	
External dimensions	Approx. 231 (W) X 289 (D) X 186 (H) mm 9.1 (W) X 11.4 (D) X 7.3 (H) inch	
	Unit: mm (inch) <p>Approx. 231 (9.1)</p> <p>Approx. 186 (7.3)</p> <p>Approx. 289 (11.4)</p>	
Weight	Approx. 3.5 kg (7.7 lb.)	
Accessories	Test label paper, CD-ROM, head cleaner, power cord, media holder bar and media shaft	
Option	Cutting unit, peeler unit, LAN board, wireless LAN	

\*1, \*2: Options can be separately purchased.

\*3: It is equipped with UFST™ and TrueType™ rasterizer that are licensed from Agfa Corporation.

TrueType™ is a trademark of Apple Computer.

UFST™ and TrueType™ rasterizer are licensed from Agfa Corporation.

UFST™ is a trademark of Agfa Corporation. TrueType™ is a trademark of Apple Computer.

\*4: Datamax® is a registered trade mark of Datamax Bar Code Products Corporation.

## Interfaces

This printer is connected to a computer and prints according to commands sent from the computer.

There are three types of computer interfaces, and these are connected to devices suited to each type of interface. The printer can also be connected to a computer by the optional Ethernet (LAN) and wireless LAN(WiFi).

### Serial Interface

#### Specifications

System	Start/stop asynchronous duplex communication
Signal level	RS-232C
Baud rate	2400, 4800, 9600, 19200, 38400, 57600, 115200bps
Bit length	7Bit, 8Bit
Stop bit	1Bit 2Bit
Parity	Odd, even, none
Connector	D-SUB 25PIN

#### Signal line and pin arrangement

Pin No.	Signal code	Signal name	Function
1	FG	Protective grounding	Protective grounding
2	TXD	Transmitted data	Signal line that transmits data from the printer to other devices
3	RXD	Received data	Signal line that transmits data from other devices to the printer
4	RTS	Transmission request	Pull up to +12V through 3.3k $\Omega$
5	NC	-----	Not used
6	DSR	Data set relay	Signal line that is active when an external device can interface with the printer
7	SGND	Signal line ground	Shows the ground level of the signal line
8-19	NC	-----	Not used
20	DTR	Data terminal relay	Signal line that is active when an external device can interface with the printer
21-24	NC	-----	Not used
25	VCC	+5V	(FACTRY USE ONLY )

### XON/XOFF Protocol

#### Requirements to output X-ON code

- Communication is possible when the power is on.
- When the receive buffer has less than 2K byte available, XOFF code is output, then the receive buffer has at least at least 4K bytes available.

#### Requirements to output the X-OFF code

- When the receive buffer has less than 2K bytes available

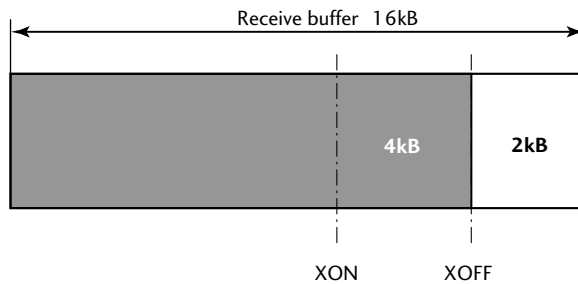

### DTR Protocol

#### Conditions when the DTR signal is “Ready (High)”

All the following conditions are satisfied.

- The receive buffer is 2K byte or more available capacity.
- \* When the receive buffer has less than 2K byte available and the DTR signal has changed to BUSY (Low) status, BUSY status is maintained until the capacity of the receive buffer has reached 4 Kbytes or more.

#### Conditions when DTR signal is “Busy (Low)”

- When the receive buffer has fallen to less than 2K byte available.

## Parallel Interface

### Specifications

Transmission mode	8-bit parallel data
Receive buffer size	16kB
Transmission modes	<p><b>Compatible mode</b> It is an asynchronous forward direction of the byte width (from host to printer) channel, and the interface line of the data is operated in accordance with signal line definitions of Centronics.</p> <p><b>NIBBLE mode</b> Nibble mode is asynchronous reverse channel communication with data transmission controlled by the host computer. In reverse channel transmission, the data is nibble transmitted in two parts using four status lines (Fault, Select, PE, and Busy). And nibble mode can be used along with compatible mode to send data in two directions.</p> <p><b>ECP mode</b> ECP mode permits bi-directional asynchronous data transmission, and thanks to its interlock handshake, it does not require the timing necessary with compatible mode.</p>
Signal level	IEEE1284 standard

### Signal line and pin assignment table

Pin No.	Signal name	I/O	Function
1	*STROBE	Input	Strobe signal to read in 8-bit data
2-9	DATA1-8	Input	8-bit parallel signal
10	*ACKNLG	Output	8-bit data request signal
11	BUSY	Output	Signal specifying printer busy
12	PERROR	Output	Signal specifying media out
13	SELECT	Output	Signal specifying if the printer is on-line (printing enabled) or off-line (pausing)
14	AUTOFD	Input	Invalid (ignored)
15	NC	---	Not used
16	GND	---	Signal ground
17	FGND	---	Frame ground
18	PL.H	Output	Peripheral logic high (pull up to +5V at 1.2kΩ)
19-30	GND	---	Ground for twisted pair return
31	*INIT	Input	Printer reset
32	*FAULT	Output	Signal specifying printer error
33-35	NC	---	Not used
36	SELECTIN	Input	Invalid (ignored)

# Appendixes

## Interfaces

### Parallel port status signals when an error occurs

Under the specifications for this bi-directional parallel interface, the parallel port status signals when an error occurs are, as shown below, partially processed differently than with compatible mode used up till now. When both are on in the setting menu, even if a printer error has occurred, the BUSY signal line is not active ("H").

Error	Change in the status of a signal line	
	Both directions OFF	Both directions ON
Paper end	Busy : L → H PError : L → H Select : H → L nFault : H → L	Busy : L → unchanged PError : L → H Select : H → unchanged nFault : H → L
Error other than paper end • Head open • Other	Busy : L → H PError : L → unchanged Select : H → L nFault : H → L	Busy : L → unchanged PError : L → unchanged Select : H → unchanged nFault : H → L
Conditions for Busy	<ul style="list-style-type: none"> <li>• Receive buffer full</li> <li>• Data being read</li> <li>• Error</li> </ul>	<ul style="list-style-type: none"> <li>• Receive buffer full</li> <li>• Data being read</li> </ul>

### Compatible timing specification

[When power is on] (Time it goes off-line)

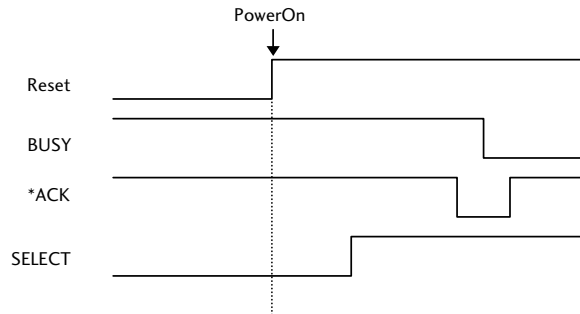

[While receiving data]

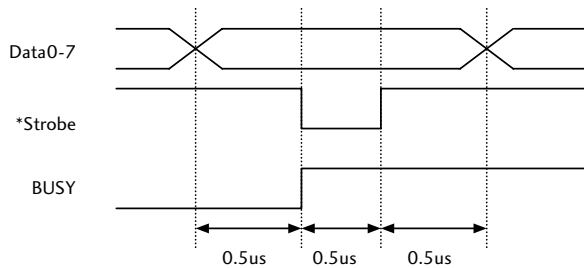

Note: Busy rises when \*Strobe signal starts, and data is latched with \*Strobe signal starts.

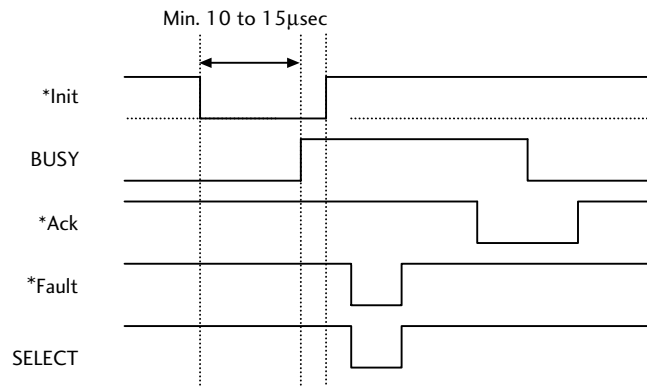
**[While receiving INIT signal]**

Note: If the \*Init signal does not have width of 10 to 15 μsec or more, it cannot act as an Init signal. If it is lower, the \*Init signal is ignored. BUSY starts up when the \*Init signal is perceived.

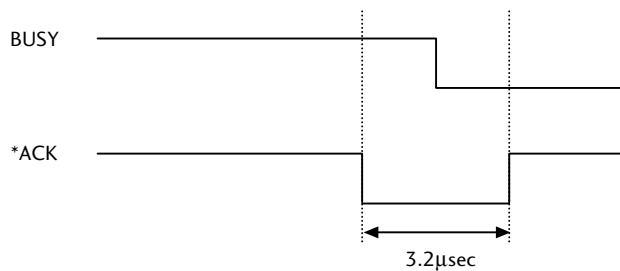
**Relation of the timing of the BUSY signal and the \*ACK signal  
[Center - ACK]**

### USB Interface

#### Specifications

Standards	Complies with Universal Serial Bus Specification
Transmission speed	Compatible with 12Mbps (full speed) transmission
Receive buffer	16kB
Connector	DUSB DUSB-BRA42-T11 (DDK)

#### Signal line and pin arrangement

Pin No.	Signal code	Signal	Function
1	VBUS	USB power	USB power (+5V)
2	D+	Signal line +	+ signal line
3	D-	Signal line -	- signal line
4	GND	GND	GND

## Replacing the Interface Board

### Caution

Always turn off the power to the printer before replacing the interface board. Do not pull it out with unnecessary force. This will cause an accident.

### Replacement Method

1. Remove the screws (2) that anchor the bracket of the interface board then pull the interface board towards you. When you do this, be careful not to perform any unreasonable operations that will damage the connecting cable and do not pull the cable too much. If you do, it will cause a malfunction.

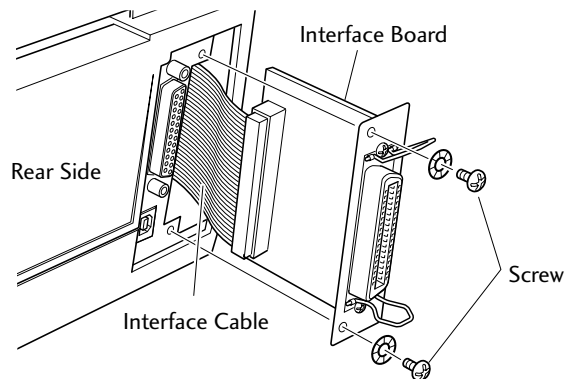

2. Remove the connecting cable from the interface board and reconnect the cable to the connector of the replacement interface board

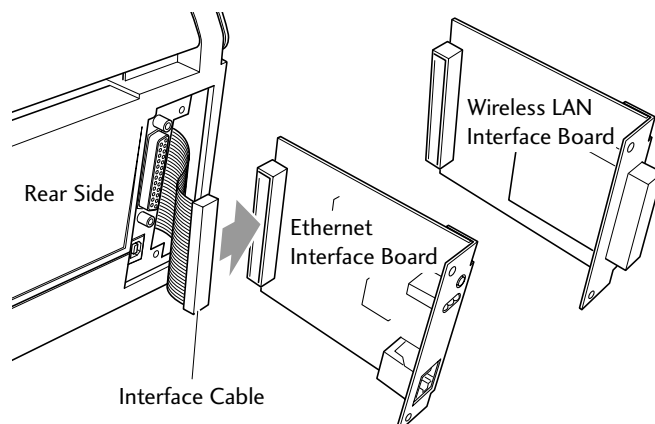

# Appendixes

## Replacing the Interface Board

3. Insert the interface board into the printer so that the connecting cable does not catch on the printer, then use the screws (2) that you removed to anchor the bracket.

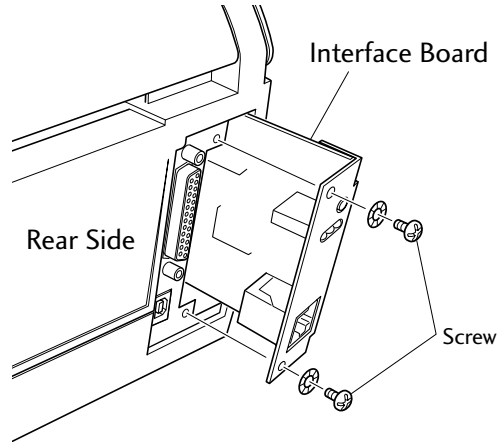



## **Citizen America Corporation**

2102 Alton Parkway, Unit A  
Irvine, CA 92606  
Tel: (949) 428-3700  
U.S.A.

## **Citizen Systems Europe GmbH**

Park House, 643-651 Staines Road	Mettinger Strasse 11
Feltham, Middlesex, TW14 8PA	D-73728 Esslingen
United Kingdom	Germany
Tel: +44 (0) 20 8893 1900	Tel: +49 (0) 711 3906 400
<a href="http://www.citizen-europe.com">http://www.citizen-europe.com</a>	

## **Japan CBM Corporation**

CBM Bldg., 5-68-10, Nakano  
Nakano-ku, Tokyo 164-0001  
Tel: (+81-3) 5345-7540  
Fax: (+81-3) 5345-7541